



Instruction manual

Electrobloc EBL 99 G

Type no. 911.417

Table of contents

1	Introduction	2
2	Safety information	2
3	Description and appropriate use	3
4	Suitable accessories (not supplied)	4
5	Electrical data.	4
6	Operation	5
7	Maintenance.	7
8	Shutting down the system	7
9	Changing the battery	8
10	Technical faults, possible causes and remedies	9
11	Customer service	10
12	Block diagram - for specialist workshop only	11
13	Fault report.	12

1 Introduction

This instruction manual contains important information for safe operation of the Electrobloc. It is essential to read and to follow the given safety information.

The instruction manual should always be kept in the motorhome/caravan. All safety information must be passed on to other users.



- ▲ Failure to comply with this sign may lead to the endangerment of persons.



- ▲ Failure to comply with this sign may damage the device or the connected consumers.



- ▲ This sign indicates recommendations or special features.

The reproduction, translation and duplication of this manual, even in parts, is not allowed without written authorization.

2 Safety information

The design of the Electrobloc is state-of-the-art and according to approved safety technology. Nevertheless, if the safety information in this instruction manual is not closely followed, persons might get injured or the Electrobloc might be damaged.

Do not use the Electrobloc if it is not in technically good order and condition. The instruction manual must be followed.

Any technical faults affecting the safety of persons or of the Electrobloc must be dealt with immediately by qualified personnel.



- ▲ The electrical system of the motorhome or the caravan has to meet current DIN, VDE and ISO regulations. Manipulations of the electrical system will endanger the safety of persons and the vehicle, and are therefore prohibited.
- ▲ Never make any modifications to the Electrobloc.
- ▲ The electrical connection may only be established by qualified personnel and must be carried out according to the Schaudt installation instructions.
- ▲ Connection work is to be carried out in tensionless condition only.
- ▲ Risk of fatal injury due to electric shock or fire in the case of a defective mains cable or incorrect connection!
- ▲ Risk of fatal injury!
Never perform maintenance on the Electrobloc when it is live.
- ▲ Blown fuses must only be replaced when the cause of the fault is known and eliminated.
- ▲ Never bridge or repair fuses.
- ▲ Danger of burning! Blown fuses must only be changed on a zero-current Electrobloc.
- ▲ Only use original fuses rated as specified in the instruction manual.



- ▲ Danger of burning! During operation the back of the Electrobloc gets hot. Do not touch.
- ▲ Danger of explosion from formation of detonating gas due to an incorrectly set battery selector switch, defective batteries, defective Electrobloc or an excessively high battery working temperature (more than 30 °C).



- ▲ The AES refrigerator fuse may only be used if a AES refrigerator is connected. Otherwise, the living area battery may get totally discharged. Battery damage is possible.
- ▲ An incorrectly set battery selector switch damages the living area battery.
- ▲ Disconnect the Electrobloc from the mains before adjusting the battery selector switch.
- ▲ If the living area battery is separated from the Electrobloc using the 12 V main switch at the control and switch panel, the frost protection valve of the heater system opens. Water may be lost. For more information, see the instruction manual of the heater system.
- ▲ Before and after shutdown, the living area battery must be fully recharged to avoid battery damage. For this purpose the vehicle must be connected to mains supply for a minimum of 12 hours with an 80 Ah battery and 24 hours with a 160 Ah battery.
- ▲ Do not operate the Schaudt solar charge regulator without a battery. This might damage the solar charge regulator or any connected consumers. If the battery is going to be changed or removed, please first take off the positive lead "+ Solarzelle" (+ Solar Module) on the solar charge regulator.
- ▲ To avoid voltage peaks during warm-up, do not connect the generator until it is running in a stable manner. Otherwise, the Electrobloc, the 12 V consumers or other connected equipment might get damaged. It is essential that the generator complies with the mains supply specifications.
- ▲ The mains supply on board car ferries might not always be perfect. Therefore, never connect the Electrobloc to the mains on car ferries. Otherwise, the Electrobloc, the 12 V consumers or other connected equipment might get damaged.

3 Description and appropriate use

The Electrobloc EBL 99 G is designed as a main power distributor for motorhomes/caravans. The Electrobloc is a permanent installation. The Electrobloc is for charging batteries and supplying 12 V appliances with power.

The electrical management system Electrobloc EBL 99 G consists of:

- The LAS 1218 charger module
- The 12 V distribution
- Fuses for the 12 V circuits
- A battery monitor module
- Other control and monitoring functions

The charger module is a primary controlled switch-mode power supply. This modern switching technology achieves high charging performance at a compact size and low weight.

A control and switch panel has to be connected for operation. This control and switch panel controls the electrical functions in the living area of in the motorhome, including accessories.

There are connections for an auxiliary charging unit and a solar charge regulator.

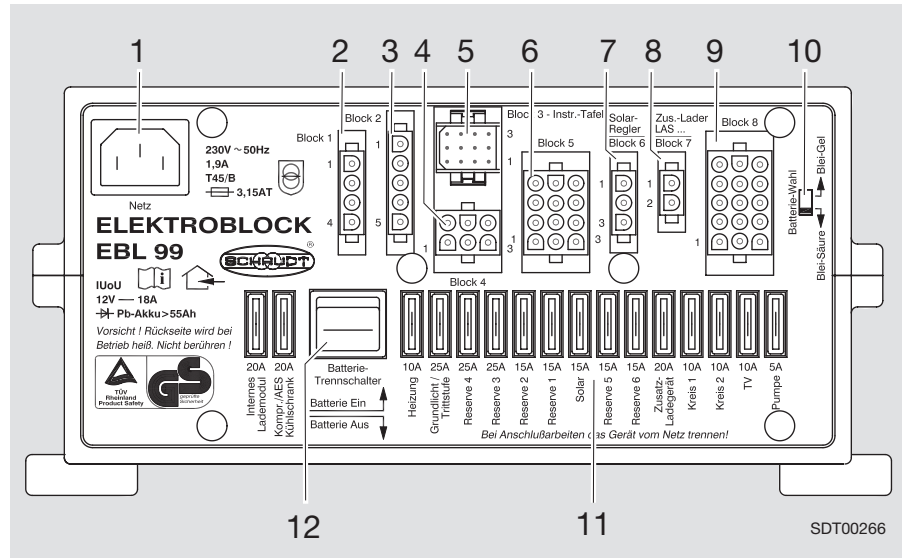

Fig. 1 Electrobloc EBL 99 G, front view

- 1 Mains connection
- 2 Connections for refrigerator
- 3 Connections for refrigerator power supply, D+ and sensor/control wires
- 4 Connections for frost protection valve, heater and floor light/step
- 5 Connections for control and switch panel
- 6 Spare connections
- 7 Connections for solar charge regulator
- 8 Connections for auxiliary charging unit
- 9 Connections for TV, pump and other consumers
- 10 Battery selector switch
- 11 Flat vehicle fuses
- 12 Battery cut-off switch

4 Suitable accessories (not supplied)

- Control and switch panel**
- IT 20-2, IT 20-3, IT 95, IT 901, IT 991, IT 992, IT 993
 - LT 410, LT 99, LT 993

and their variants

- Auxiliary charging unit** Schaudt battery charging unit type LAS... with up to 18 A charge current
Additional 2-pin charging cable, lengths supplied on request

- Solar charge regulator** Schaudt solar charge regulator type LR... for solar modules with a total current of 14 A with 3-pin connector plug, including 0.5 m cable

5 Electrical data

Mains connection 230 V AC \pm 10 %, 47 to 63 Hz sinusoidal, protection class I

Suitable batteries 6-cell lead acid or lead gel batteries of at least 55 Ah

Current-carrying capacity 12 V outputs No more than 90 % of the rated current of the appropriate fuse may be drawn, see the block diagram.

6 Operation

6.1 Operating controls

Flat vehicle fuses



- ▲ Blown fuses must only be replaced when the cause of the fault is known and eliminated.
- ▲ Never bridge or repair fuses.
- ▲ Danger of burning! Blown fuses must only be changed on a zero-current Electrobloc.
- ▲ Only use original fuses rated as specified in the instruction manual.

The flat vehicle fuses protect the various circuits.

Battery cut-off switch

The battery cut-off switch "Batterie Ein/Aus" (battery on/off) disconnects the following connections from the living area battery:

- All 12 V consumers
- The frost protection valve
- The control and switch panel

This prevents the living area battery from slowly discharging due to closed circuit current while the vehicle is not in use.

The batteries can still be charged using the Electrobloc, the alternator, an auxiliary charging unit or the solar charge regulator, even when the battery cut-off switch is switched off.



- ▲ Before starting up:
 - Make sure the living area battery is connected.
 - Make sure the battery selector switch is set for the correct type of battery.
 - Make sure the AES fuse is only used if the AES refrigerator is connected. Otherwise, the living area battery may get totally discharged. Battery damage is possible.

Start up the system

- Set the battery cut-off switch on the Electrobloc to "Batterie Ein" (battery on).
- After switching on the battery cut-off switch or after changing batteries: Switch on the 12 V main switch on the control and switch panel briefly to start up the consumers.

Shutting down the system



- Set the battery cut-off switch to "Batterie Aus" (battery off).
- ▲ When the living area battery is separated from the Electrobloc by the battery cut-off switch, the frost protection valve of the heater system opens. Water may be lost. For more information, see the instruction manual of the heater system.

Battery selector switch



- ▲ Danger of explosion from formation of detonating gas due to an incorrectly set battery selector switch, defective batteries, defective Electrobloc or an excessively high battery working temperature (more than 30 °C).



- ▲ An incorrectly set battery selector switch damages the living area battery.
- ▲ Disconnect the Electrobloc from the mains before adjusting the battery selector switch.

The switching option provided by the battery selector switch ensures optimum charging of the two different types of battery, lead acid and lead gel. The switch must be set to the correct battery type: lead acid or lead gel.

Use a thin object (e. g. a ballpoint pen cartridge) to move the battery selector switch.

- Set lead gel battery: Set the battery selector switch to "Blei-Gel" (lead gel).
- Set lead acid battery: Set the battery selector switch to "Blei-Säure" (lead acid).

12 V main switch (on the control and switch panel)

The 12 V main switch on the control and switch panel switches all consumers and the panel on and off.

Exceptions:

- Heater
- Floor light/step
- Frost protection valve
- AES/compressor refrigerator
- Spare 4

For more information, see the instruction manual of the control and switch panel.

6.2 Additional functions

Automatic switch function for AES/compressor refrigerator

This relay supplies the AES/compressor refrigerator with power from the starter battery when the vehicle engine is running and the D+ connection is live. An AES/compressor refrigerator is powered by the living area battery when the vehicle engine is switched off.

Mains charging of starter battery

This feature provides an automatic float charge for the starter battery at up to 2 A when the 230 V mains is connected to the Electrobloc.

6.3 Battery monitor

Automatic disconnecter

The battery monitor compares the voltage of the living area battery to a reference voltage. As soon as the battery voltage falls below 10.5 V, all 12 V consumers are switched off via the main switch relays 1 and 2. Only the frost protection valve is still powered. The automatic disconnecter is not triggered by short-term low voltage (less than 2 seconds), caused by high current when switching on consumers.

If an overload or an insufficiently charged living area battery causes the voltage to fall so low that the automatic disconnecter is triggered, any consumers which are not essential should be switched off.

You may be able to switch on the 12 V power supply for a short time. To do this, switch on the 12 V main switch on the control and switch panel.

However, if the battery voltage remains below 11.0 V, you cannot switch the 12 V power supply back on.

Fully charge up the living area battery as soon as possible. For more information see the description of battery voltage.

7 Maintenance

The Electrobloc requires no maintenance.

Cleaning

Clean the Electrobloc with a soft, slightly damp cloth and mild detergent. Never use spirit, thinners or similar substances. Do not allow fluid to penetrate the inside of the Electrobloc.

8 Shutting down the system



- ▲ Before and after shutdown, the living area battery must be fully recharged to avoid battery damage. For this purpose the vehicle must be connected to mains supply for a minimum of 12 hours with an 80 Ah battery and 24 hours with a 160 Ah battery.
- ▲ Do not operate the Schaudt solar charge regulator without a battery. This might damage the solar charge regulator or any connected consumers. If the battery is going to be changed or removed, please first take off the positive lead "+ Solarzelle" (+ Solar Module) on the solar charge regulator.



- ▲ When the living area battery is separated from the Electrobloc by the battery cut-off switch, the frost protection valve of the heater system opens. Water may be lost. For more information, see the instruction manual of the heater system.

Disconnecting the living area battery from the 12 V power supply

Disconnect the living area battery from the 12 V power supply if you are not going to use the motorhome for a lengthy period (for example during the winter).

- Switch off the 12 V main switch on the control and switch panel.
- Set the battery cut-off switch on the Electrobloc to "Batterie Aus" (battery off).
- Remove the plug "+ Solarzelle" (+ Solar Module) on the solar charge regulator, if the battery is going to be removed.
- Pull out the fuse for the AES refrigerator.



- ▲ The living area battery can also be charged using the internal charger module, an auxiliary charging unit, the solar charge regulator and the alternator when the battery cut-off switch is switched off.

9 Changing the battery



- ▲ Batteries may only be changed by qualified personnel.
- ▲ Follow the instructions of the battery manufacturer.
- ▲ To disconnect the battery from the Electrobloc, all you need to do is set the battery cut-off switch on the Electrobloc to "Batterie Aus" (battery off).
- ▲ Charging unsuitable types of battery may irreparably damage them.
- ▲ Only use the Electrobloc for connecting the 12 V power supply to 6-cell lead gel or lead acid batteries.

Only use batteries of the same type and capacity and those installed by the manufacturer.

You can change from lead acid to lead gel batteries.

You cannot change from lead gel to lead acid batteries. Ask your dealer for advice.



- ▲ Danger of explosion from formation of detonating gas due to an incorrectly set battery selector switch, defective batteries, defective Electrobloc or an excessively high battery working temperature (more than 30 °C).



- ▲ An incorrectly set battery selector switch damages the living area battery.
- ▲ Disconnect the Electrobloc from the mains before adjusting the battery selector switch.

The switching option provided by the battery selector switch ensures optimum charging of the two different types of battery, lead acid and lead gel. The switch must be set to the correct battery type: lead acid or lead gel.

Use a thin object (e. g. a ballpoint pen cartridge) to move the battery selector switch.

- Set lead gel battery: Set the battery selector switch to "Blei-Gel" (lead gel).
- Set lead acid battery: Set the battery selector switch to "Blei-Säure" (lead acid).

Starting up the system

- Set the battery cut-off switch on the Electrobloc to "Batterie Ein" (battery on).
- After switching on the battery cut-off switch or after changing batteries: Switch on the 12 V main switch on the control and switch panel briefly to start up the consumers.

10 Technical faults, possible causes and remedies

If you are unable to solve a fault using the following tables, please contact our customer service address.

If this is not possible, e. g. if you are abroad, you can have the Electrobloc repaired at a specialist workshop.

Inexpert repairs invalidate the guarantee for the Electrobloc and Schaudt GmbH takes no liability for any resulting damage.

Fault	Possible cause	Remedy
Living area battery is not charged during 230 V operation (battery voltage constantly below 13.3 V)	No mains voltage	Switch on the automatic fuse in the vehicle
		Have the mains voltage checked
	Defective Electrobloc	Call customer service
Living area battery is over-charged during 230 V operation (battery voltage constantly above 14.5 V)	Defective Electrobloc	Call customer service
Starter battery is not charged during 230 V operation (battery voltage constantly below 13.0 V)	No mains voltage	Switch on the automatic fuse in the vehicle
		Have the mains voltage checked
	Defective Electrobloc	Call customer service
Living area battery is not charged during mobile operation (battery voltage below 13.0 V)	Defective alternator	Have the alternator checked
	No voltage at D+ input	Have the fuse and wiring checked
	Defective Electrobloc	Call customer service
The living area battery is overcharged during mobile operation (battery voltage constantly above 14.3 V)	Defective alternator	Have the alternator checked
The refrigerator does not work during mobile operation	No power supply to the refrigerator	Have the fuse and wiring checked
	Defective Electrobloc	Call customer service
	Defective refrigerator	Have the refrigerator checked
Solar charger does not work (power supply and engine are off)	Solar charge regulator not plugged in	Plug in the solar charge regulator
	Defective fuse or wiring	Have the fuse and wiring checked
	Defective solar charge regulator	Have the solar charge regulator checked

Fault	Possible cause	Remedy
12 V power supply in the living area does not work	12 V main switch for the living area battery is switched off	Switch on the 12 V main switch for the living area battery
	Battery cut-off switch is switched off	Switch on the battery cut-off switch
	Defective fuse or wiring	Have the fuse and wiring checked
	Defective Electrobloc	Call customer service



- ▲ If the device becomes too hot due to excessive ambient temperature or lack of ventilation, the charging current is automatically reduced. However, always prevent the device from overheating.
- ▲ If the automatic shutdown mechanism of the battery monitor is triggered, fully charge up the living area battery.

11 Customer service

Customer service address Schaudt GmbH, Elektrotechnik & Apparatebau
 Daimlerstraße 5
 88677 Markdorf
 Germany

Phone: +49 7544 9577-16

Email: kundendienst@schaudt-gmbh.de

Opening hours Mon to Thu 8 to 12 a.m., 1 to 4 p.m.
 Fri 8 to 12 a.m.

- Sending in the device** Returning a defective device:
- Always use well-padded packaging.
 - Fill in and enclose the fault report, see section 13.
 - Send it to the addressee delivered free.

Disposal instruction When the product service life is over, dispose of the device in accordance with the applicable regulations.

12 Block diagram - for specialist workshop only

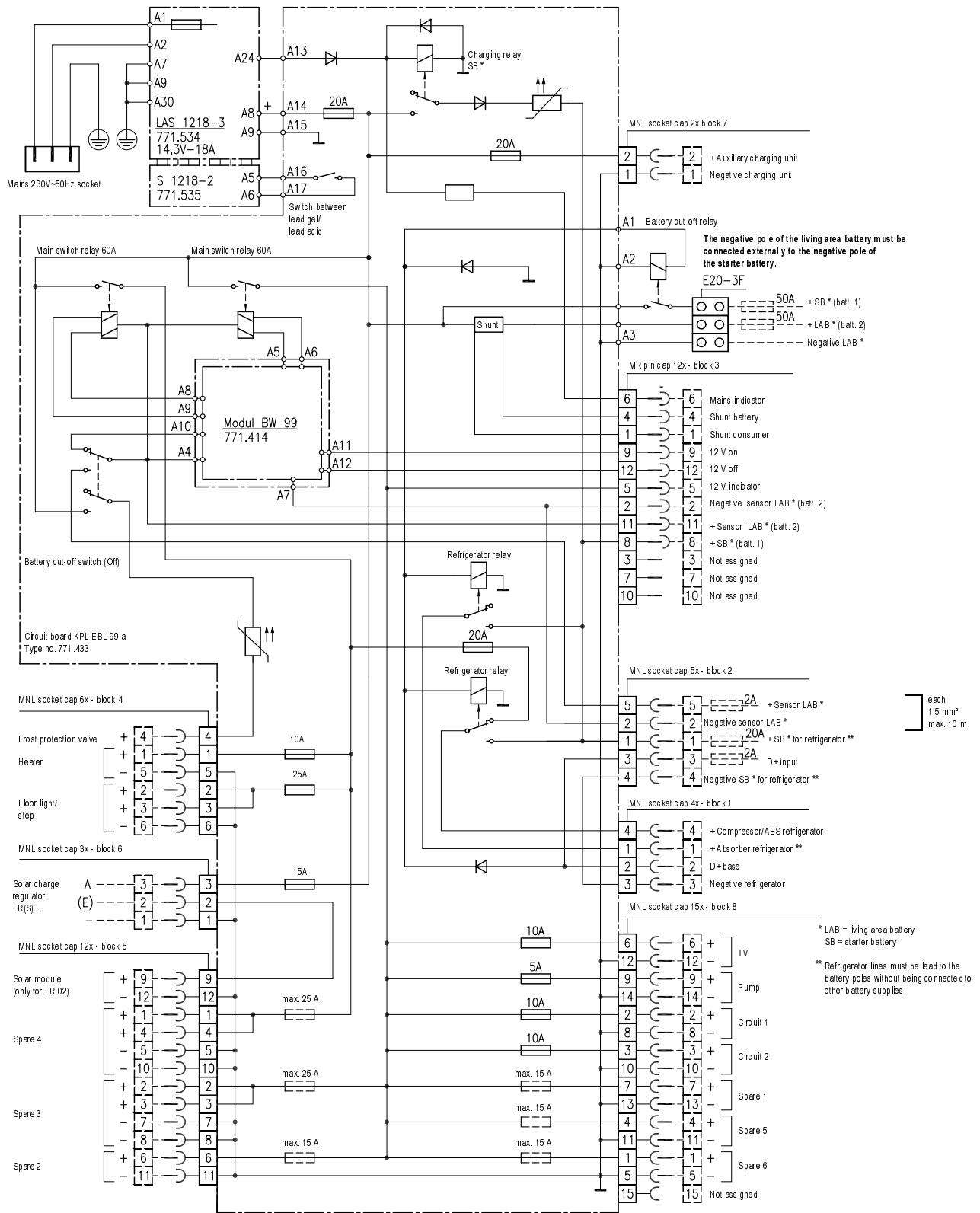

SDT00233

Fig. 2 Block diagram of Electrobloc EBL 99 G

13 Fault report

In the event of damage, please return the defective device together with the completed fault report.

Device type: EBL 99 G
 Type no.: 911.417

There is the following defect:
 (please tick)

Battery not being charged during power operation	<input type="checkbox"/>						
Battery not being charged during mobile operation	<input type="checkbox"/>						
The following electrical consumers do not work:	<input type="checkbox"/>						
Malfunction of control and switch panel	<table border="1"> <tr> <td>Tank</td> <td><input type="checkbox"/></td> <td>Voltage</td> <td><input type="checkbox"/></td> <td>Current</td> <td><input type="checkbox"/></td> </tr> </table>	Tank	<input type="checkbox"/>	Voltage	<input type="checkbox"/>	Current	<input type="checkbox"/>
Tank	<input type="checkbox"/>	Voltage	<input type="checkbox"/>	Current	<input type="checkbox"/>		
Constant fault	<input type="checkbox"/>						
Temporary fault/loose contact	<input type="checkbox"/>						

Other remarks:
